

IRD KEYNOTE SPEECH

FROM WORCESTER TO THE WORLD

Paul Riches



FROM WORCESTER TO THE WORLD

Important Numbers

- 135
- 640
- 1,286,752,879,110

What is significant about these numbers?

- 135 years in the Long Rolling Business
- 640 (Mills installed globally)
- 1,286,752,879,110m* of 5.5mm rolled on Primetals produced Wire rod mill

LETS PUT THIS into PERSPECTIVE!

Earth to Mars - 220,000,000m
 Earth to Jupiter - 606,673,805m
 Earth to Saturn - 1,353,709,936m

Approx 30,000 times around the earth!

*estimated based on annual production before 1960 -200,000mt/y after 1960 – 500,000 mt/y



Charles Hill Morgan

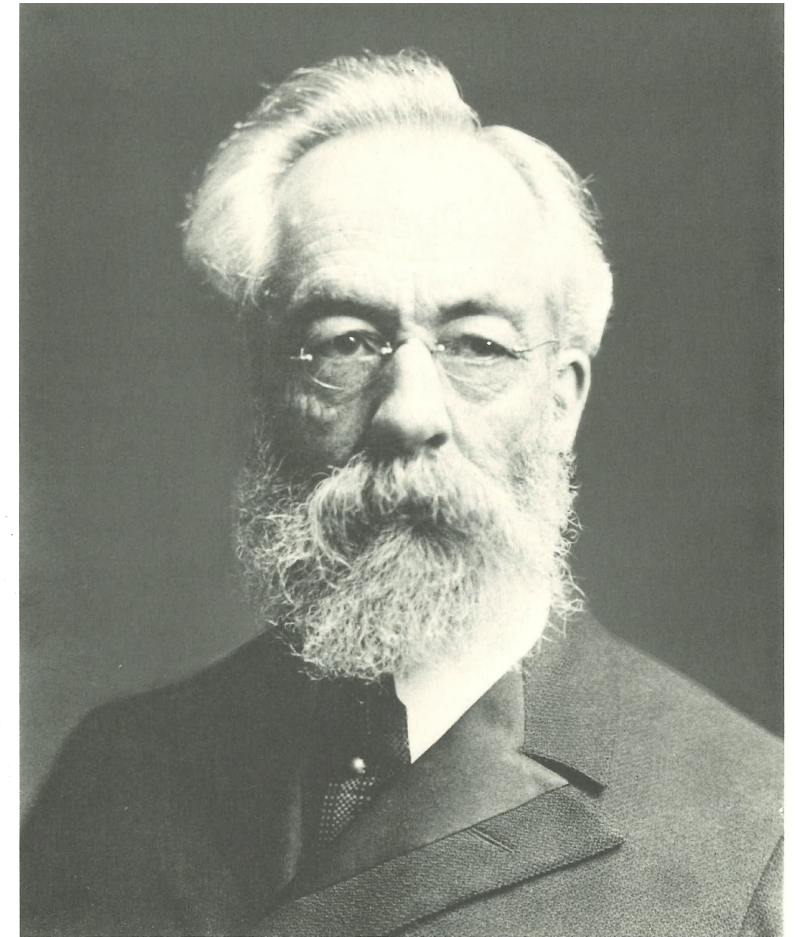
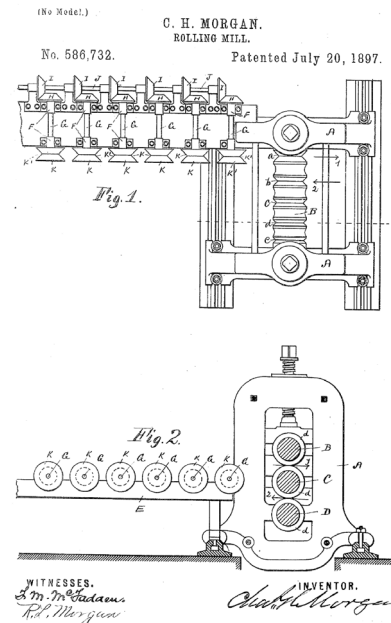
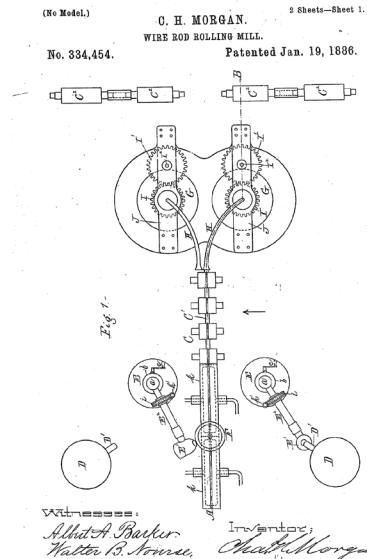
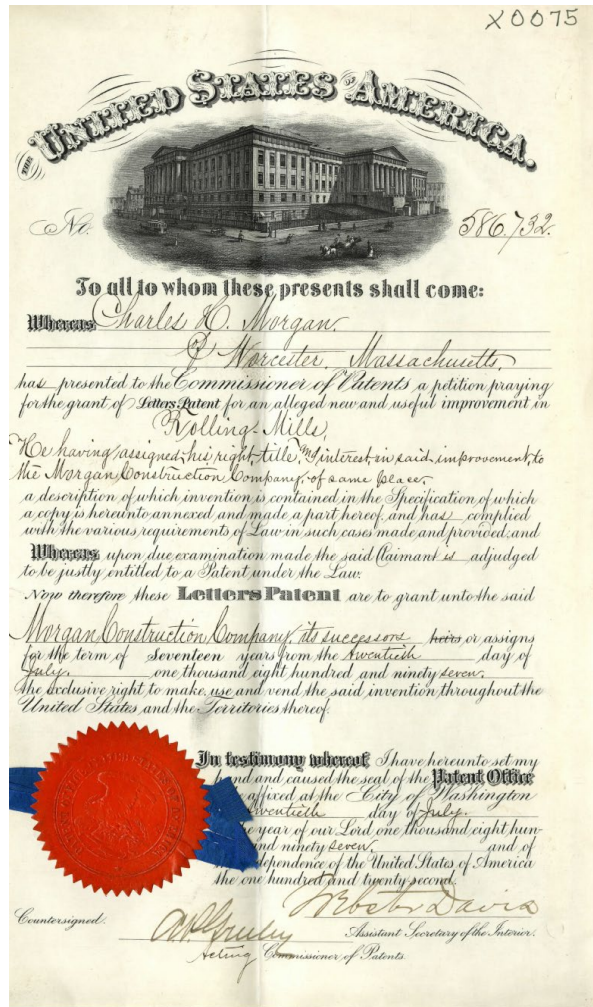

Charles Hill Morgan
President, 1888-1911

Nothing man makes is perfect for if it suits the conditions and demands of today, conditions and demands may soon change, so the engineer must be on the alert and scrutinize his own work or his competitors and customers will surely criticize.

Charles Hill Morgan

Morgan Continuous Rod Mill - 1878

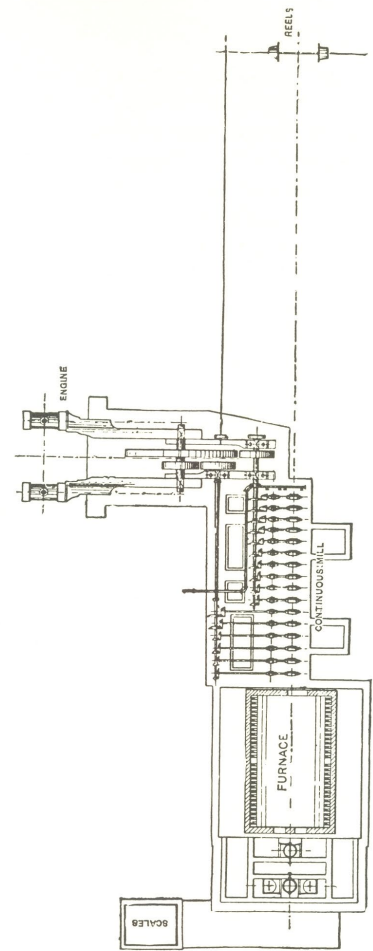
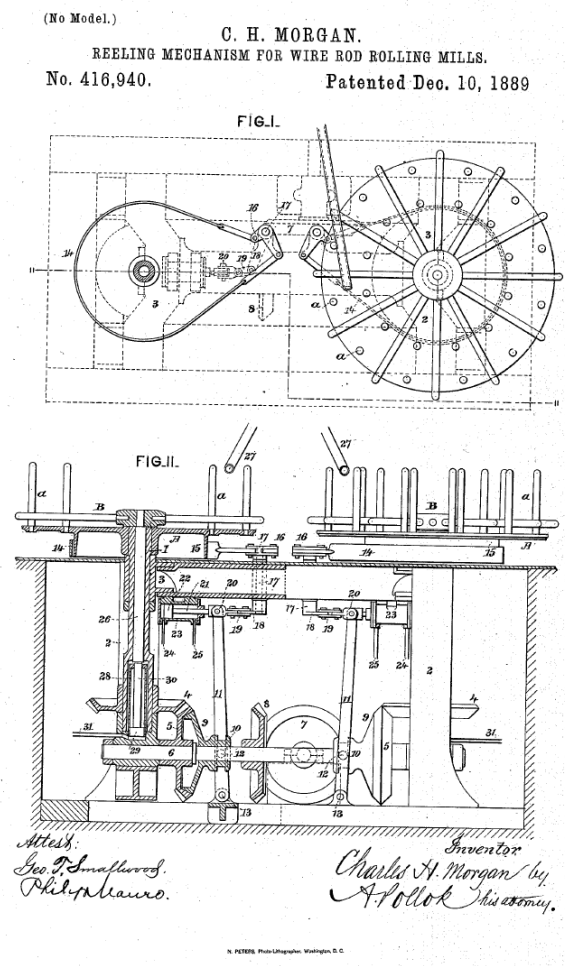

Morgan Continuous Rod Mill 1878

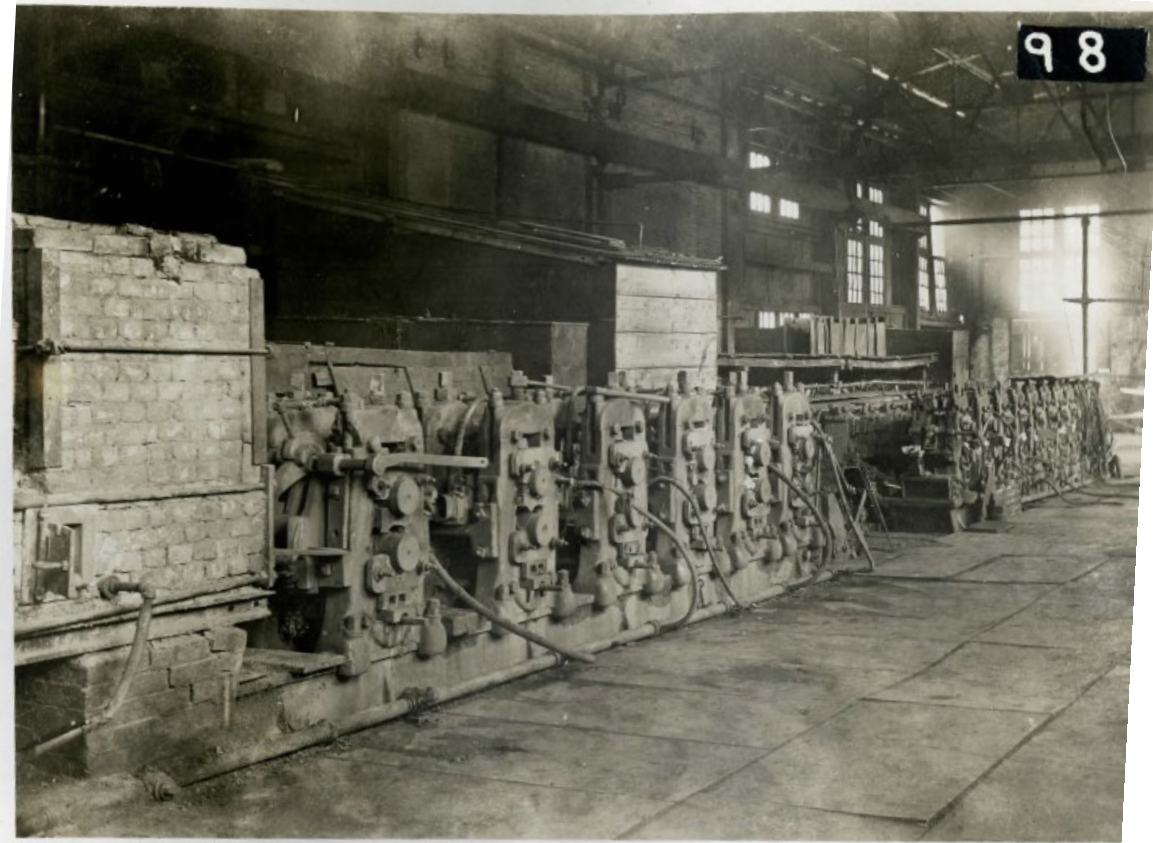

1888

MILL NUMBER 1
 CONTINUOUS ROD FINISHING MILL
 AMERICAN STEEL AND WIRE COMPANY
 CLEVELAND, OH

25 Mills between 1888 and 1902

CONTINUOUS BILLET MILLS.

Jones & Laughlins, Pittsburg, Pa.,	500 gr. tons	1½"-3" billets,	1893
Carnegie Steel Co., Duquesne, Pa.,	800 " "	1½"-3" "	1898
" " " " " "	1200 " "	1½"-3" "	1901
National Steel Co., Youngstown, O.,	1500 " "	1½"-3" "	1901
Sharon Steel Co., Sharon, Pa.,	700 " "	1¾" "	1901
Grand Crossing Tack Co., Chicago,	400 " "	1¾" "	1902

CONTINUOUS WIRE ROD, HOOP AND COTTON TIE MILLS.

American Steel & Wire Co., Cleveland, O.,	150 gr. tons	No. 5 rods	1888
American Steel Hoop Co., Youngstown, O.,	{ 100 " "	cotton tie	1895
" " " " " "	{ 120 " "	hoops	
Illinois Steel Co., Joliet, Ill.,	{ 200 " "	No. 5 rods	1898
" " " " " "	{ 100 " "	cotton tie	
Grand Crossing Tack Co., Chicago,	160 " "	No. 5 rods	1900
Wickwire Bros., Cortland, N. Y.,	160 " "	No. 5 rods	1901
Sharon Steel Co., Sharon, Pa.,	480 " "	No. 5 rods (two mills)	1901

MERCHANT MILLS.

Jones & Laughlins, Ltd., Pittsburg, Pa.,	11"-200 gr. tons	in lengths up to 220 ft.	1893
" " " " " "	13"-400 " "	" " " "	300 " 1900
" " " " " "	10"-250 " "	" " " "	350 " 1900
Ætna Standard Iron & Steel Co., Mingo Junction, O.,	11"-200 " "	" " " "	240 " 1895
Oliver Iron & Steel Co., Pittsburg, Pa.,	11"-200 " "	" " " "	220 " 1893
Guest, Keene & Co., England,	11"-200 " "	" " " "	300 " 1900
Carnegie Steel Co., Duquesne, Pa.,	10"-275 " "	" " " "	450 " 1901
" " " " " "	13"-450 " "	" " " "	450 " 1901
Illinois Steel Co., Milwaukee, Wis.,	Roughing train for 8" mill		1902
Republic Iron and Steel Co., Youngstown, O.,	" " " "	7" " "	1902
" " " " " "	" " " "	8" " "	1902
" " " " " "	" " " "	10" " "	1902

Total, 25 mills.

Production in each case is for a period of 24 hours.

MORGAN CONSTRUCTION COMPANY, WORCESTER, MASS., U. S. A.

ARE EXCLUSIVE MANUFACTURERS OF

CONTINUOUS BILLET MILLS,
CONTINUOUS MERCHANT MILLS,
CONTINUOUS HOOP MILLS,
CONTINUOUS COTTON TIE MILLS,
CONTINUOUS WIRE ROD MILLS,
CONTINUOUS AND FLYING SHEARS,
CONTINUOUS GAS PRODUCERS.

ALSO MANUFACTURERS OF

CONTINUOUS HEATING FURNACES,
CONTINUOUS WIRE DRAWING MACHINERY.

Continuous Processes Lend Themselves to Continuous Profits.

Crescent Street Factory Expansion 1950/1960

Development of the Laying Reel - 1961



Bird's-eye view

To get this excellent shot of the new Crescent Street addition, Clarence Flodine stood on the roof of a shed in the yard of Wood Lumber Co. across the street.

Sept. 7, 1965 M. MORGAN 3,204,940
 APPARATUS FOR COOLING HOT METAL ROD IN A LAYING REEL
 Filed Nov. 28, 1961 2 Sheets-Sheet 1

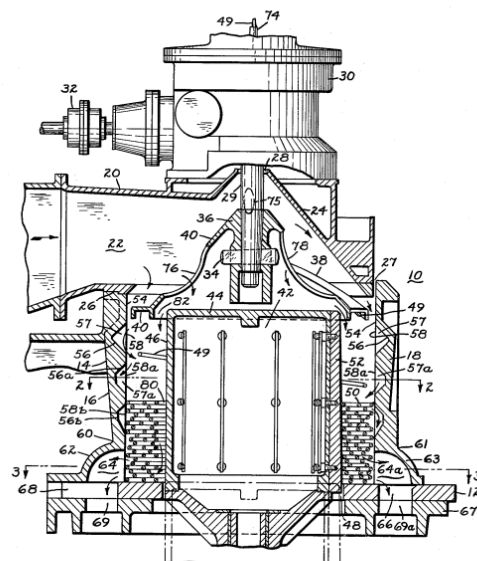
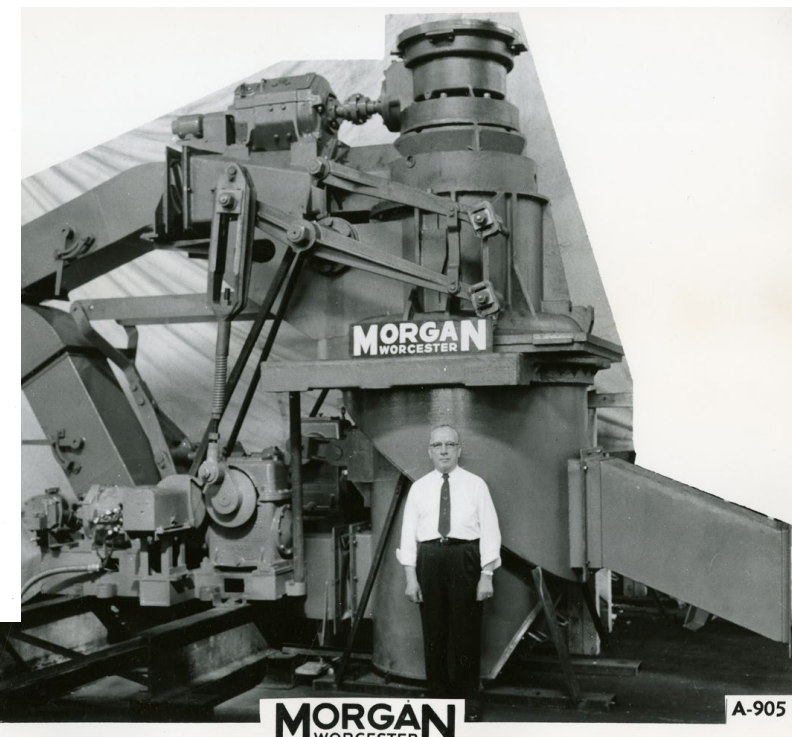
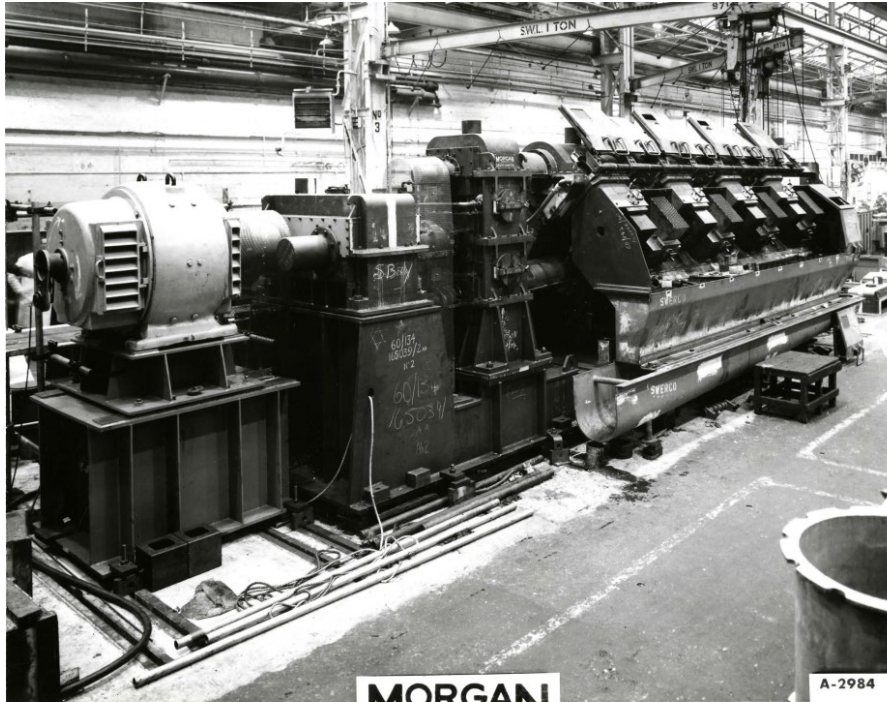

Fig. 1

INVENTOR
 Myles Morgan



1967 - Morgan "K type" No Twist Mill Shop Testing 1969 – Morgan Stelmor Conveyor Patent's



July 1, 1969 D. W. McLEAN ET AL 3,452,785
 APPARATUS FOR DEPOSITING AND CONVEYING ROD RINGS
 IN SEQUENCE WITH ROD FORMING MEANS
 Filed Dec. 7, 1965 Sheet 7 of 4

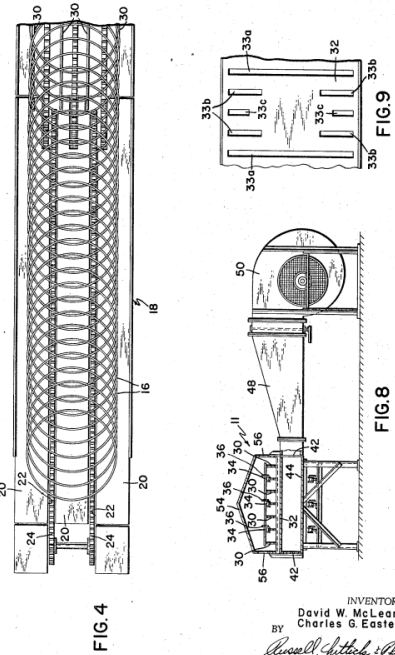

INVENTORS
 David W. McLean
 Charles G. Easter
 BY
Russell Mitchell, Jr.
 ATTORNEYS

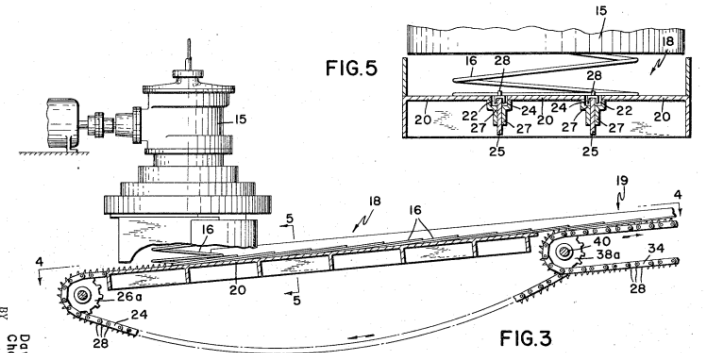

INVENTORS
 David W. McLean
 Charles G. Easter
 BY
Russell Mitchell, Jr.
 ATTORNEYS

July 1, 1969 D. W. McLEAN ET AL 3,452,785
 APPARATUS FOR DEPOSITING AND CONVEYING ROD RINGS
 IN SEQUENCE WITH ROD FORMING MEANS
 Filed Dec. 7, 1965 Sheet 2 of 4

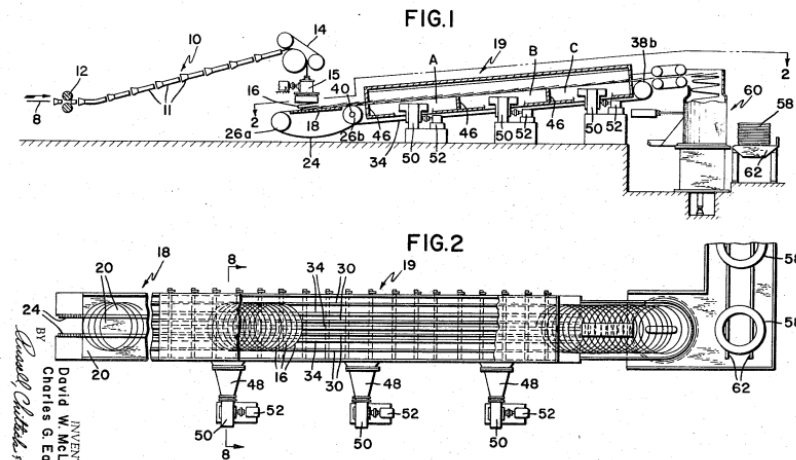

INVENTORS
 David W. McLean
 Charles G. Easter
 BY
Russell Mitchell, Jr.
 ATTORNEYS

July 1, 1969 D. W. McLEAN ET AL 3,452,785
 APPARATUS FOR DEPOSITING AND CONVEYING ROD RINGS
 IN SEQUENCE WITH ROD FORMING MEANS
 Filed Dec. 7, 1965 Sheet 1 of 4

What has the rolling mill done!

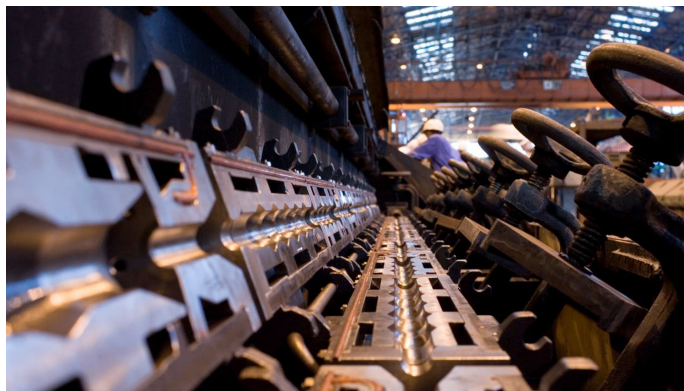
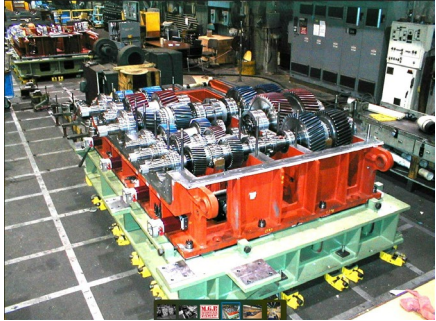

Digitization Robotics

- REPETATIVE, ARDUOUS, LABOR-INTENSIVE WORK - Robots
- Vision Systems – the e”eyes in the mill!



• Trim and Sample

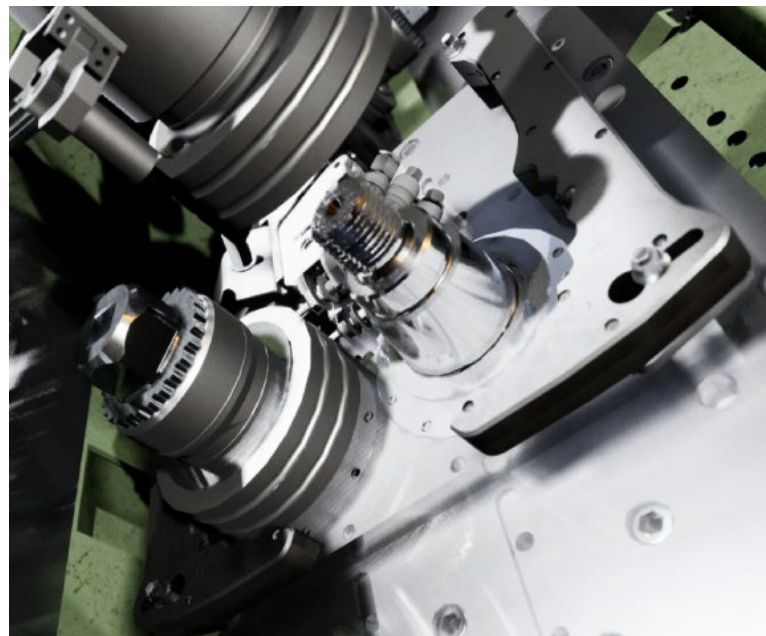

• Roll Change

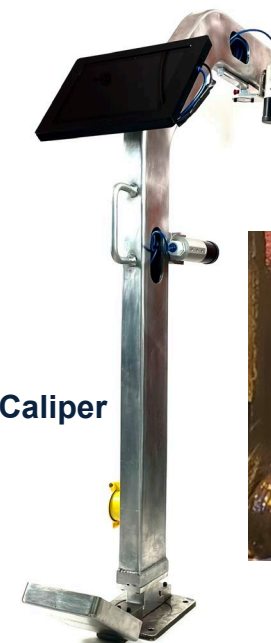

Digital Caliper

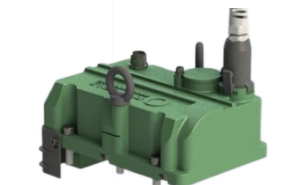
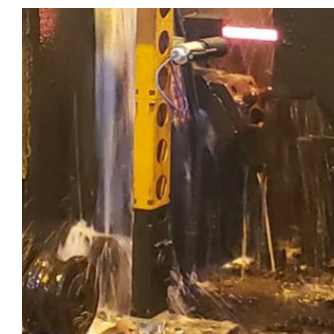

SMART Guide



• Product measurement

WPI HISTORY WITH PRIMETALS TECHNOLOGIES (MORGAN CONSTRUCTION COMPANY)

Charles Hill Morgan

Founder of Morgan Construction Company (1888)

One of the first trustees of WPI upon its creation (1865)

Morgan Family Legacy

More than 5 generations of Morgan family have served as Trustees at WPI. Phillip Morgan is still serving on it to this day.

One of WPI most generous benefactors over the years.

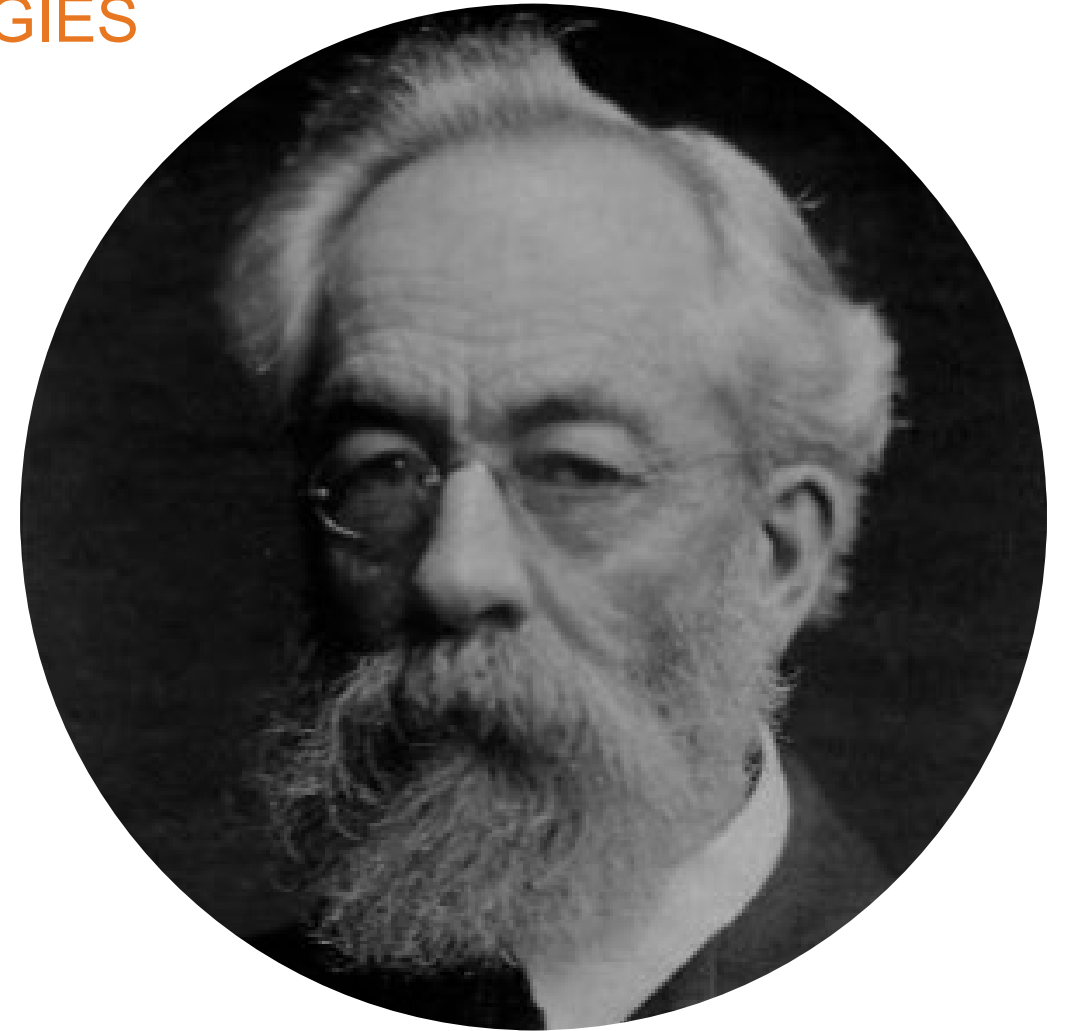
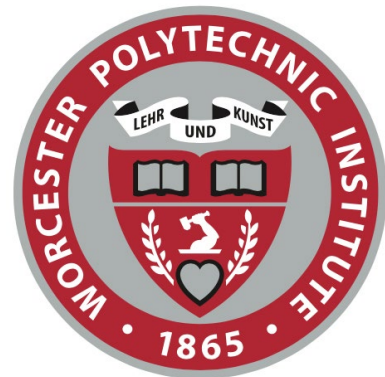

Charles Hill Morgan – Founder Morgan Construction Company

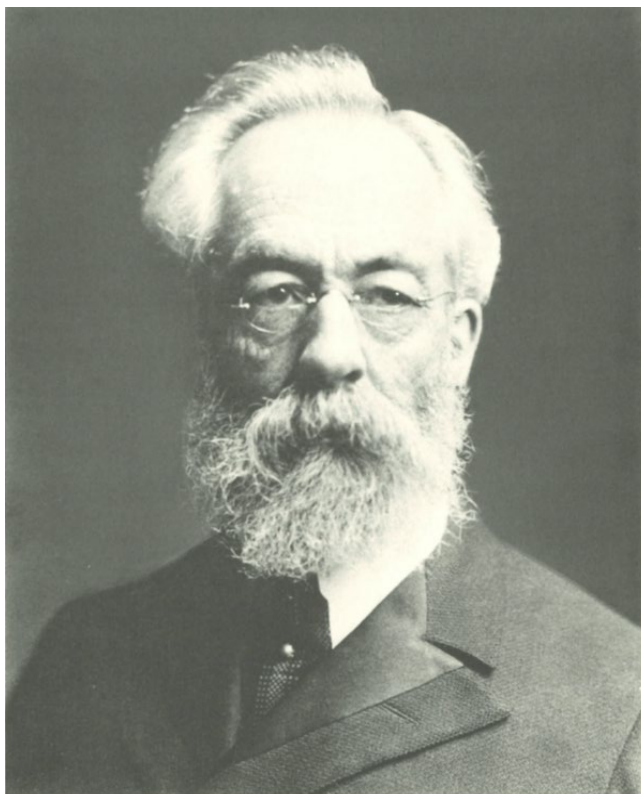

Charles Hill Morgan
President, 1888-1911

Nothing man makes is perfect for if it suits the conditions and demands of today, conditions and demands may soon change, so the engineer must be on the alert and scrutinize his own work or his competitors and customers will surely criticize.

Charles Hill Morgan

“The best advertisement in the World is a sound product”

“The building of special precision machinery that must be accurately made and very carefully applied is a complicated process.

In the design of a mill a great deal of attention must be paid to the minutest details to obtain the greatest operating efficiency and reduce time lost for roll and size changes to a minimum”

C.H. Morgan 1990