



# LASERBOND®

PRODUCTIVITY | INNOVATION | CONSERVATION



## COMPOSITE CARBIDE STEEL MILL ROLLS

Peter Mutty – International Sales Manager – IRD, Fort Wayne

# A BRIEF OVERVIEW OF LASERBOND LTD

- ❑ Commenced business in 1997 as HVOF Australia, based in Sydney, Australia
- ❑ Focus on refurbishing in Earthmoving, Mining, Steel, Aluminum, Power Gen.
- ❑ Founders foresaw a need for a process offering low heat input combined with a metallurgical bond – LASER!
- ❑ Purchased first laser power system in 2002. Developed into a fully CNC controlled, powder fed Laser Cladding system in-house
- ❑ HVOF Australia went public in 2007 to raise funds to finance growth of business. Changed name to LaserBond Ltd
- ❑ Now running 5 Laser Cladding Systems. Two facilities covering 6,500 sq yds. Employing approx 70 people. Turning over US\$16m
- ❑ 3 Income Streams: Products, Technology, Services
- ❑ In-House Lab (ESM). QA - ISO 9001. Strong R & D (Uni ToF-SIMS) Mapping



# LASERBOND SYDNEY SHOP – 5,500 SQ YDS





# CNC TURN/GRIND/MILL, HVOF, PLASMA, VFHT, LASER



# POINT OF DIFFERENCE

- Thorough knowledge of how carbides are sitting
- Off Axis & Co-Axial Heads – flexibility
- In-House lab to develop best cladding parameters
- Culture of constant improvement – R & D
- Ability to blend powders ‘on-the-fly’. Custom Alloys to suit very specific environments
- Super high speed deposition = ability to compete against price on thicker hard chrome deposits

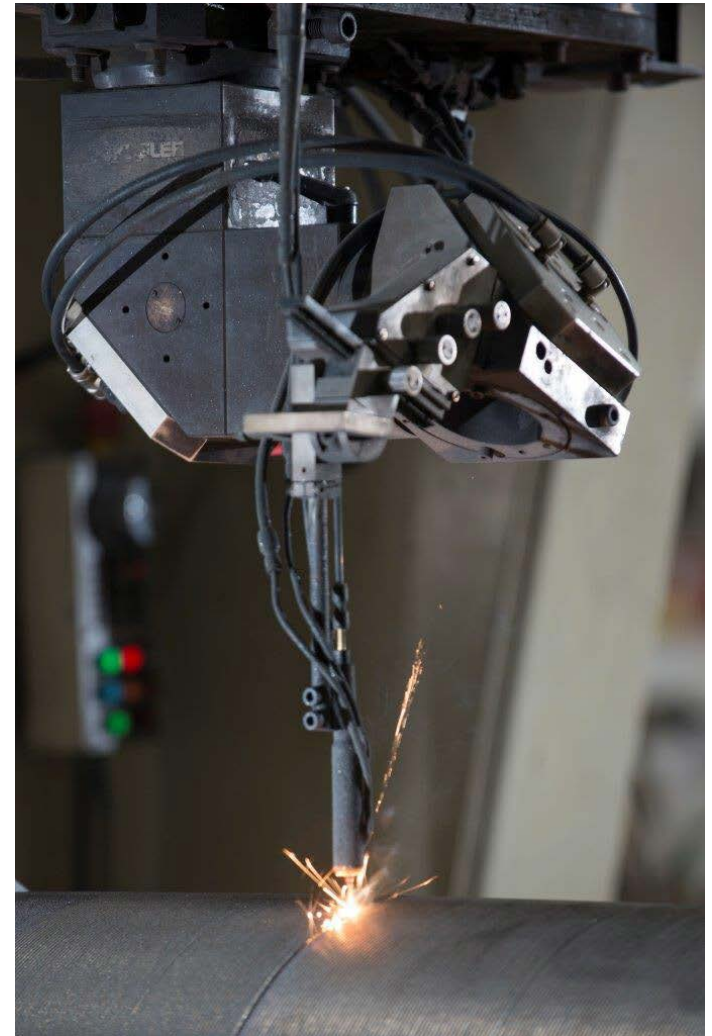



STANDARD LASER CLAD DEPOSIT – HIGH FERRITE COUNT,  
UNEVEN CLADDING, DE-NATURING OF CARBIDES, HIGH DILUTION

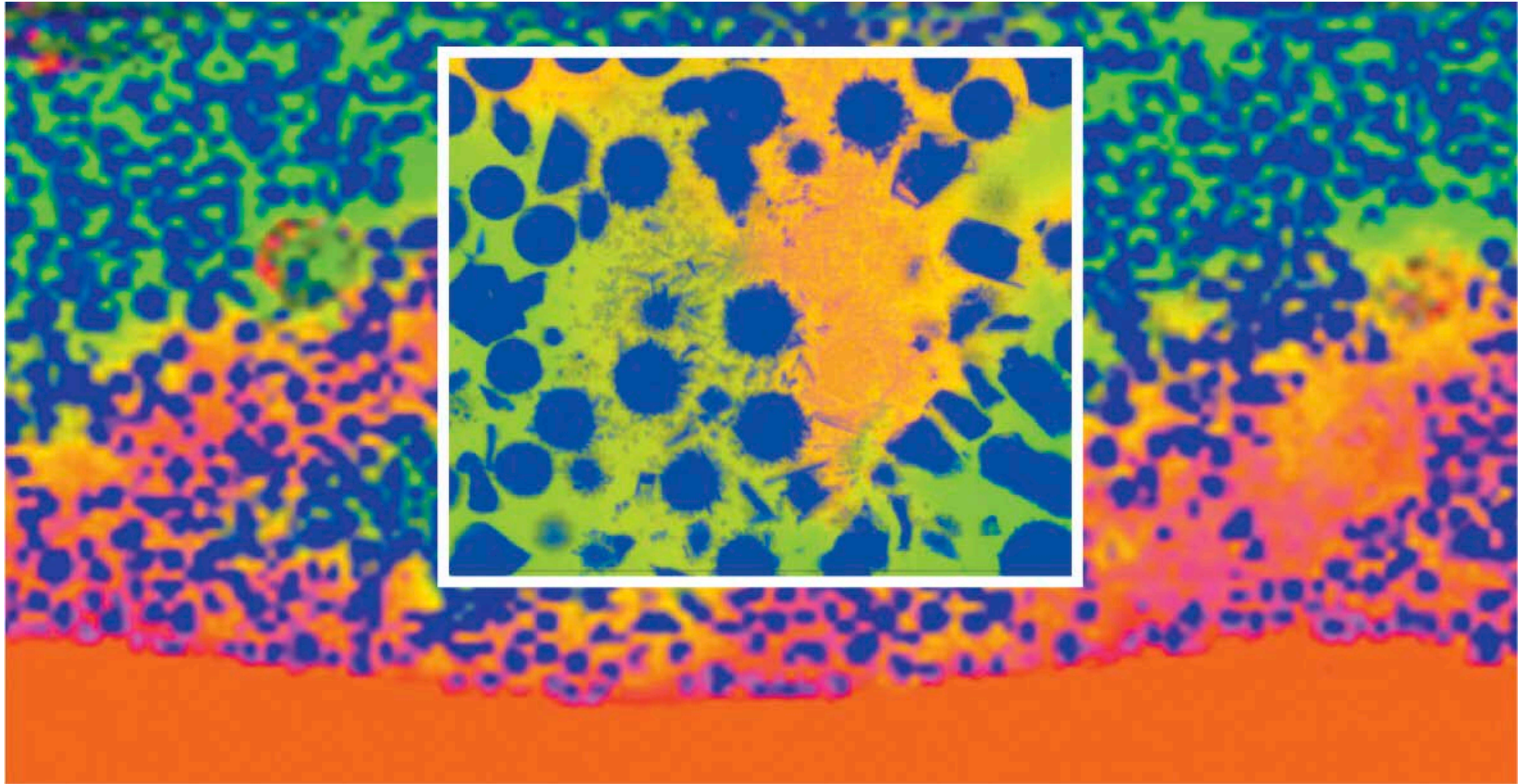



LASERBOND CLADDING – GLOBAL PATENT PENDING, HIGH WC  
CONCENTRATION, EVENNESS OF DISTRIBUTION, THIN HAZ

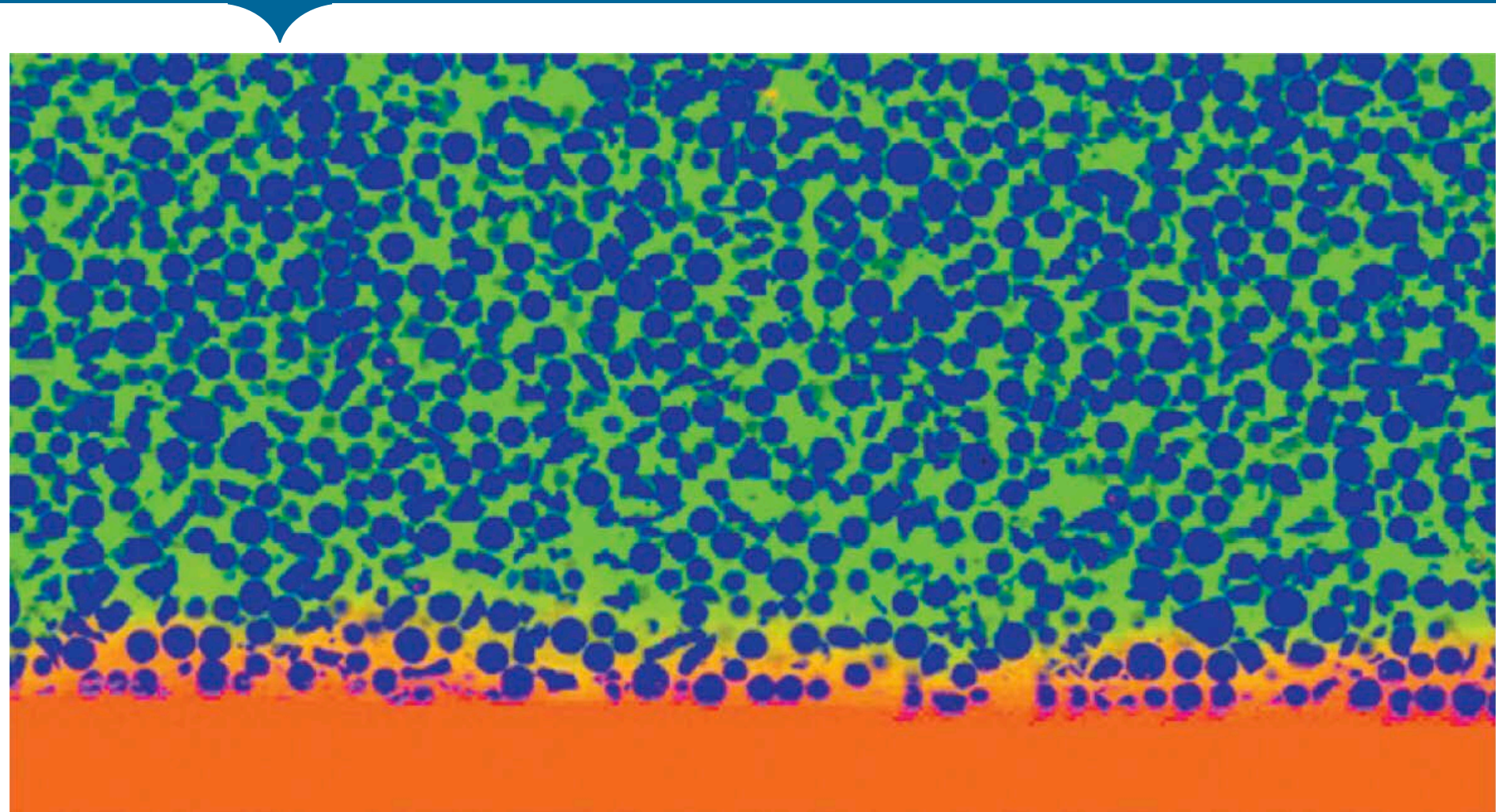

# THE BEGINNING OF MINI MILLS FOR LASERBOND

Liberty Steel - 'You will be hero's if you can solve our wear problem with Cantilever Rolls'.

First 3 we laser clad are still in service nearly 3 years later!

Running rebar and flat product





**Now manufacturing and laser cladding:**

**Persuader Rolls**

**Run-In, Run-Out Rolls**

**Table Rolls**

**Trough Rolls**

**Idler Rolls**

**Looper Rolls**

**Pinch Rolls**

**Aligning Rolls**

**Triple Slit Rolls**

**Maxibar Rolls**

**All relatively lightweight and low freight cost component.**

# SPRAYED WITH CORROSION RESISTANT COATING, SECURELY PACKED





# EARLY FEEDBACK

## **Email from Nucor Mill 3/28/19**

FYI. We installed the last of the RT6 rolls that you sent us. 1 roll ran backwards for a week and there is not one mark/groove on the roll. So far, I am impressed.

## **Email from a different Nucor Mill 1/18/19**

One of the rolls got a good test last week. A bearing failed so the roll locked up. As a result, beams were drug across the roll for a period of 5 DAYS!! The roll looks as good as new despite having been subjected to this abuse. A very promising start.

'I'M MILDLY EXCITED' .....

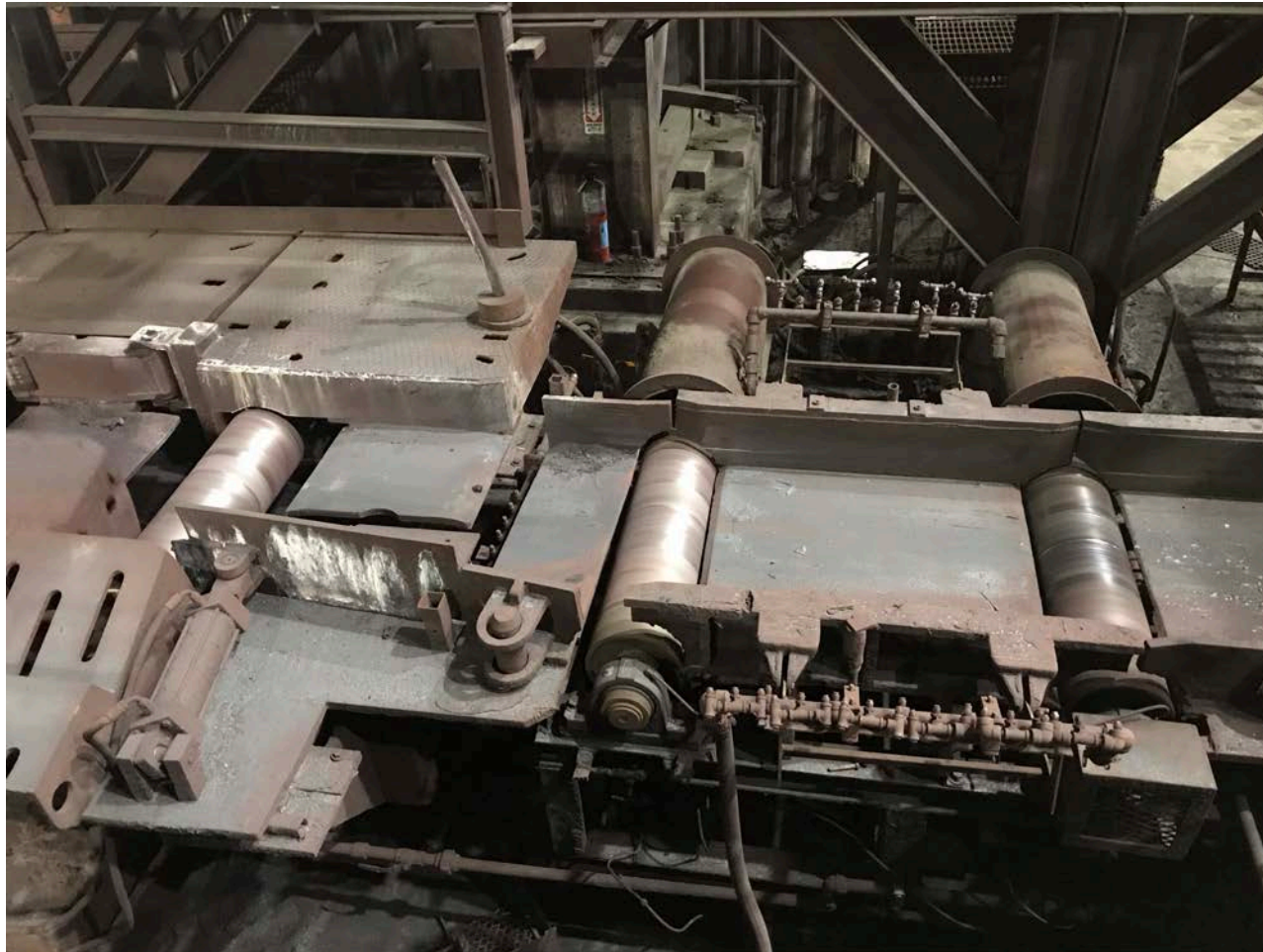



# APRONS





# LARGER ROLLS & OTHER STEEL MILL APPS IN AUSTRALIA





# LET US SEE IF WE CAN HELP REDUCE YOUR MAINTENANCE COSTS

## METERING ROLL

- Aggressive environment, wearing expensive Metering Rolls out very fast.
- Investigating option of applying composite carbide to steel sections then diamond grinding OD flush with bronze strips.



# LASERBOND COMPOSITE CARBIDE STEEL MILL ROLLS

1. Email a fully dimensioned drawing to Peter Mutty at [peterm@laserbond.com.au](mailto:peterm@laserbond.com.au)
2. We will email you back if we have any questions etc.
3. LaserBond will send you a quotation to fully manufacture the Roll / Roll Sleeve complete with Composite Carbide laser cladding (specifying 'as-Clad' or ground finish). The quotation will be presented with a single price which will include all freight, taxes and duties payable to make it as straight

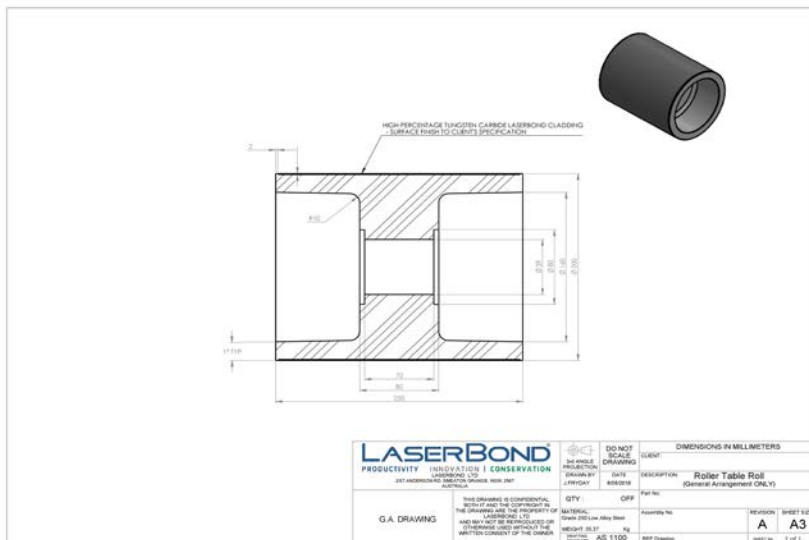

< W |

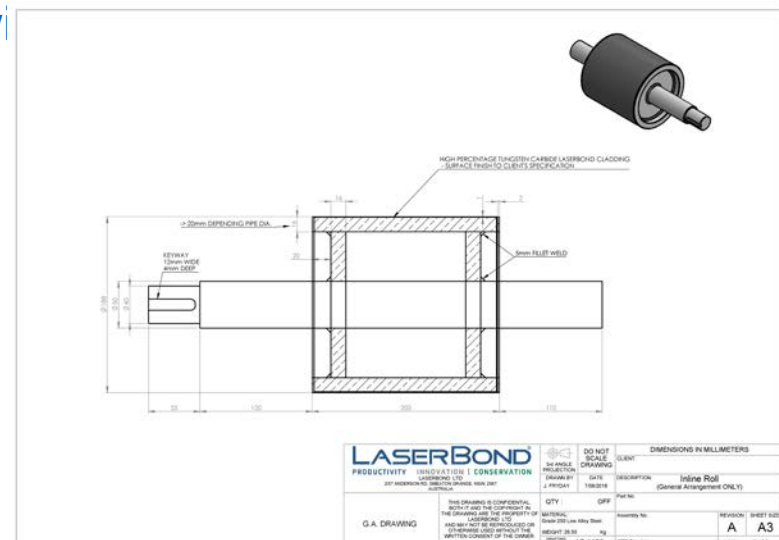



# LIBERTY STEEL - AUSTRALIA

Purchase Order - 7506107166.pdf - Adobe Acrobat Reader DC

File Edit View Window Help

Home Tools Purchase Order - 7...

LIBERTY

**Purchase order No. 7506107166**

Sydney Steel Mill  
22 Kellogg Road  
Rooty Hill  
New South Wales 2766  
Australia

Attention : GREG HOOPER  
Fax No : 1

Order Date 10.04.2019

<b>Vendor:</b> 2002347 LASERWORKS LIBERTY LASERWORKS LIBERTY 2/57 ANDERSON ROAD SMEATON GRANGE New South Wales 2567	<b>Payment Terms</b> Due 62 days after month of invoice <b>Currency</b> AUD
<b>Deliver to:</b> Sydney Steel Mill Main Store 22 Kellogg Road Rooty Hill New South Wales 2766	<b>Contact</b> Mel Yildirim Mel.Yildirim@libertyfg.com
	<b>Phone/Fax</b> 02 9675 9916 (02) 9675 9900
	<b>Delivery Instructions</b> Delivery Terms: Free into store

Ensure order no. and item no. are quoted on all invoices, packaging and delivery dockets.  
Send Inv to accpey\_po@libertyfg.com / Comm. Shared Services Locked Bag 5044 Parramatta NSW 2124

Item No.	Description / Brand	Valuation	Delivery Date	Qty	Unit Price /Per	Value Excl GST
1	Laser clad Idler rolls SMM58575 Your material number: AS PER QUOTE 27880 LINE 1 Goods Recipient: Bezuidenhout Unloading Point: Main Store		30.04.2019	42.0 EA	1,330.00 /1 EA	55,860.00
2	Laser clad Persuader rolls SMM58585 Your material number: AS PER QUOTE 27880 LINE 2 Goods Recipient: Bezuidenhout Unloading Point: Main Store		30.04.2019	11.0 EA	1,290.00 /1 EA	14,190.00
3	Laser clad Triple slit rolls SMM93103 Your material number: AS PER QUOTE 27880 LINE 3 Goods Recipient: Bezuidenhout		30.04.2019	6.0 EA	985.00 /1 EA	5,910.00

PAGE 1 OF 3

OneSteel NSW Pty Ltd ABN: 50003312882

Get legal e-signatures with Adobe Sign. Start Free Trial.

Search tools

Export PDF

Adobe Export PDF

Convert PDF file to Word or local drive

Select PDF file

Purchase O...107166.pdf

Convert to

Microsoft Word (.docx)

Document Language

English (US) Change

Convert

Create PDF

Fill PDF

Comment

Combine Files

Organize Pages

Redact

Protect

Optimize PDF

Fill & Sign

Send for Review

More tools

Windows taskbar: 6:50 AM 15/05/2019

# LIBERTY STEEL - AUSTRALIA

Purchase Order - 7506107166.pdf - Adobe Acrobat Reader DC

File Edit View Window Help

Home Tools Purchase Order - 7...

LIBERTY

**Purchase order**  
No. 7506107166

Sydney Steel Mill  
22 Kellogg Road  
Rooty Hill  
New South Wales  
2766  
Australia

Attention : GREG HOOPER  
Fax No : 1

Order Date 16.04.2019

Vendor: 2002347	Payment Terms	Currency
LASERBOND LIMITED	Due 62 days after month of invoice	AUD
LASERBOND LIMITED		
2177 ANDERSON ROAD	Contact	Phone/Fax
SMEATON GRANGE	Mel Yildirim	02 9675 9916
New South Wales 2567	Mel.Yildirim@libertygfg.com	(02) 9675 9900

Item No.	Description / Brand	Valuation	Delivery Date	Qty	Unit Price /Per	Value Excl GST
4	Unloading Point: Main Store Laser clad Maxibar rolls SMM09163 Your material number: AS PER QUOTE 27880 LINE 4 Goods Recipient: Bezuidenhout Unloading Point: Main Store		30.04.2019	6.0 EA	900.00 /1 EA	5,580.00
5	Laser clad small idler rolls SMM01451 Your material number: AS PER QUOTE 27880 LINE 5 Goods Recipient: Bezuidenhout Unloading Point: Main Store		30.04.2019	16.0 EA	840.00 /1 EA	13,440.00

The new Procurement Handbook for Suppliers is available for downloading from "www.libertygfg.com/terms-and-conditions".

The price shown on the purchase order (plus GST where applicable) will be paid to the vendor unless the nominated contact person is notified of any changes prior to delivery.

If a price has not been specified in this Purchase Order for any service item (eg. due to uncertainties surrounding the exact scope of work), the parties agree that Liberty shall not be required to pay any amount for such item in excess of what Liberty (acting reasonably), considers to be a

PAGE 2 OF 3

OneSteel NSW Pty Ltd ABN: 95003312892

Get legal e-signatures with Adobe Sign

6:49 AM 15/05/2019



# LIBERTY STEEL - AUSTRALIA

Purchase Order - 7506107166.pdf - Adobe Acrobat Reader DC

File Edit View Window Help

Home Tools Purchase Order - 7...

Search Sign In

LIBERTY

**Purchase order**  
No. 7506107166

Sydney Steel Mill  
22 Kellogg Road  
Rosty Hill  
New South Wales  
2766  
Australia

Attention : GREG HOOPER  
Fax No : 1

Order Date 10.04.2019

Vendor: 2002347 LASERBOND LIMITED LASERBOND LIMITED 21ST ANDERSON ROAD SILICAION GRANGE New South Wales 2567	Payment Terms Due 62 days after month of invoice	Currency AUD
	Contact Mel Yildirim Mel.Yildirim@libertygf.com	Phone/Fax 02 9675 9916 (02) 9675 9900

Item No.	Description / Brand	Valuation	Delivery Date	Qty	Unit Price /Per	Value Excl GST
	<p>reasonable amount plus GST where applicable in determining such amount, Liberty must have regard to usual industry practices, standards, fees and charges.</p> <p>Except to the extent that:</p> <p>(a) different terms appear on the first page of this Purchase Order; or</p> <p>(b) Liberty has agreed otherwise in writing,</p> <p>this purchase order is subject to the current Liberty Terms and Conditions for purchase of Goods and/or Services. A copy of which can be viewed on the internet web site "www.libertygf.com/terms-and-conditions".</p>					

Total Weight (KG) 0  
 Net Value 94,980.00  
 GST 9,498.00  
 Total Value (AUD) 104,478.00

OneSteel NSW Pty Ltd AFIN 0064012802

PAGE 3 OF 3

Get digital signatures with Adobe Sign. Use Free Trial

Search Tools

Export PDF

Adobe Export PDF

Comment PDF

Search PDF file

Convert to

Document Language

Convert

Create PDF

Libr PDF

Comment

Combine Files

Organize Pages

Redact

Protect

Optimize PDF

Fill & Sign

Send for Review

More Tools

Windows Taskbar: 6:47 AM 15/05/2019

# ACKNOWLEDGEMENTS

**A special THANK YOU to the following people:**

**Bobby Newcomb – Nucor Yamato**

**Mike Chociej – Herkules**

**John Ballani – Rolls & Tech Services**

**To ALL those Steel folk who have been willing to see me and hear me ramble on and then to go on and invest their company funds with LaserBond!**





# VERTICAL STRAIGHTENING ROLL









